

The Bucket Shop

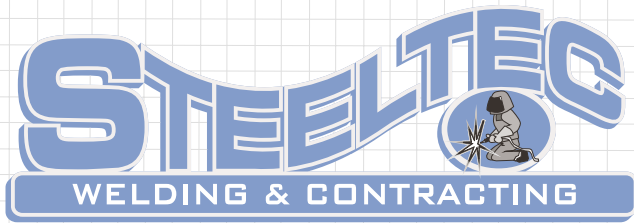

Prototype & Custom Products

Today the business of buckets for mining and construction has become somewhat of a customized business. Different properties and job sites often have unique requirements in buckets.

The Bucket Shop has a full time engineering department on standby to design buckets to your specific needs and in fact 2/3 of what we produce would be considered job specific where-by we design and manufacture custom buckets to fulfill customer requirements and "We are exceptionally good at it"!

That is to say that job specific buckets while somewhat more expensive don't have to cost an arm and leg and in fact are usually more cost effective in the long run.

We would be more than pleased to discuss your unique job requirements and what role we may play in ultimately reducing your Bucket expense.

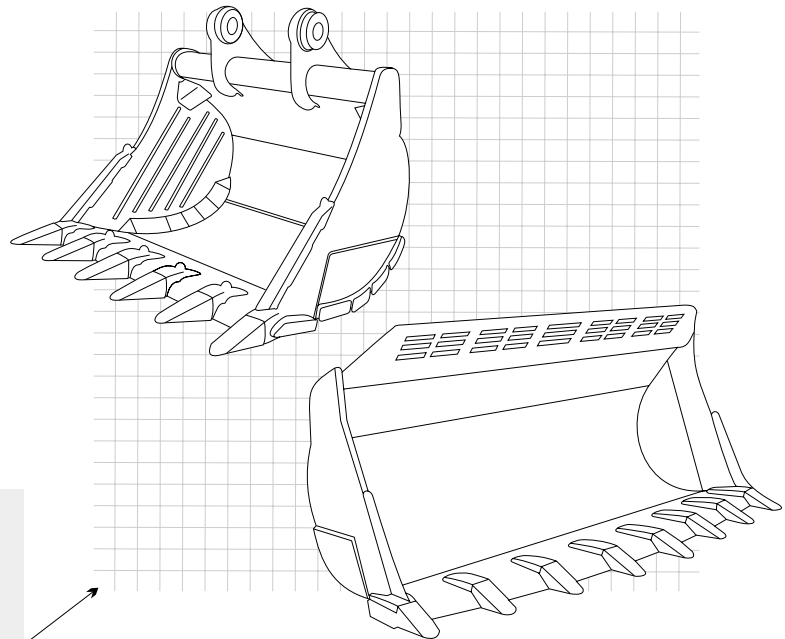

The Bucket Shop has a full time engineering department on standby to design buckets to your specific needs. 2/3 of what we produce is considered job specific, we design and manufacture custom buckets to fulfill customer requirements.